

# MODEL : BV-301M [ Three Piece Body Ball Valve Full Port ]

Connection : Butt Weld, Socket Weld, Screw BSP | NPT



VTV VALVE, serving Multi-National end users in a wide range of applications in many industries including:

1. Palm Oil and Refinery Plant
2. Food Industries
3. Rubber Glove Industries
4. Petrochemical Plant
5. Building Services

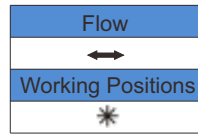

- ◆ **Suitable for :** 1. Water
- 2. Oil
- 3. Gases

### ◆ SPECIFICATION

1. Body & ends caps quality investment casting
2. With ISO 5211 direct mounting pad
3. Adjustable stem packing
4. Available in stainless steel or carbon steel
5. Blow-out proof stem design
6. Working pressure : 1000/800 psi
7. Temperature range -20°F to 450°F
8. With locking function

### ◆ MATERIAL LIST

| ITEM | PART NAME     | MATERIALS |
|------|---------------|-----------|
| 1    | END CAP       | CF8M      |
| 2    | BODY          | CF8M      |
| 3    | BALL          | SS 316    |
| 4    | SEAT          | PTFE      |
| 5    | GASKET        | PTFE      |
| 6    | BOLTS         | SS 304    |
| 7    | THRUST WASHER | RPTFE     |
| 8    | O-RING        | VITON     |
| 9    | STEM PACKING  | PTFE      |
| 10   | STEM          | SS 316    |
| 11   | GLAND         | SS 304    |
| 12   | DISK WASHER   | SS 301    |
| 13   | STEM NUT      | SS 304    |
| 14   | NUT STOP      | SS 304    |
| 15   | SPACE WASHER  | SS 304    |
| 16   | PLATER        | SS 304    |
| 17   | STOP PIN      | SS 304    |
| 18   | HANDLE NUT    | SS 304    |
| 19   | HANDLE        | SS 304    |
| 20   | SLEEVE        | PLASTIC   |

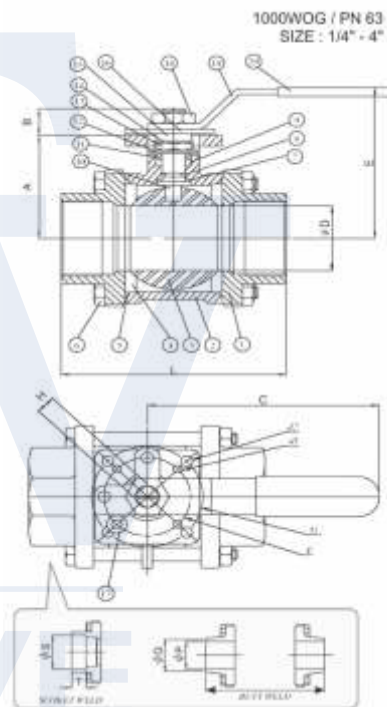

### ◆ DIMENSIONS (mm)

| SIZE   | A    | B  | C   | D    | d1   | d2   | E   | F   | G   | H  | L     | S     | T    | P   | Q    | L1   | W (kg) |
|--------|------|----|-----|------|------|------|-----|-----|-----|----|-------|-------|------|-----|------|------|--------|
| 1/4"   | 35   | 11 | 130 | 11   | 6.0  | 6.0  | 58  | 36  | 42  | 9  | 60.5  | 14.2  | 11.1 | 10  | 12.5 | 60.5 | 0.48   |
| 3/8"   | 35   | 11 | 130 | 12.5 | 6.0  | 6.0  | 58  | 36  | 42  | 9  | 60.5  | 17.5  | 11.1 | 12  | 14.5 | 60.5 | 0.48   |
| 1/2"   | 35   | 11 | 130 | 15   | 6.0  | 6.0  | 58  | 36  | 42  | 9  | 63.5  | 21.8  | 12.7 | 15  | 17.5 | 63.5 | 0.48   |
| 3/4"   | 40   | 11 | 130 | 20   | 6.0  | 6.0  | 64  | 36  | 42  | 9  | 75.5  | 27.1  | 14.3 | 20  | 22.5 | 75.5 | 0.84   |
| 1"     | 48   | 14 | 155 | 25   | 6.0  | 7.0  | 77  | 42  | 50  | 11 | 86    | 33.8  | 15.9 | 25  | 28   | 86   | 1.24   |
| 1 1/4" | 53.5 | 14 | 155 | 32   | 6.0  | 7.0  | 83  | 42  | 50  | 11 | 96    | 42.5  | 17.5 | 32  | 35   | 104  | 1.98   |
| 1 1/2" | 63.5 | 18 | 205 | 38   | 7.0  | 9.0  | 92  | 50  | 70  | 14 | 111   | 48.7  | 19.1 | 38  | 41   | 117  | 2.9    |
| 2"     | 72   | 18 | 205 | 50   | 7.0  | 9.0  | 100 | 50  | 70  | 14 | 129   | 61.1  | 22.2 | 50  | 54   | 138  | 4.42   |
| 2-1/2" | 92   | 22 | 290 | 65   | 9.0  | 11.3 | 140 | 70  | 102 | 17 | 152.5 | 73.9  | 22.2 | 65  | 70   | 170  | 9.15   |
| 3"     | 102  | 22 | 290 | 80   | 9.0  | 11.3 | 150 | 70  | 102 | 17 | 168.5 | 89.9  | 25.4 | 80  | 85   | 192  | 13.42  |
| 4"     | 32   | 26 | 335 | 100  | 11.3 | 13.5 | 195 | 102 | 125 | 22 | 212.5 | 115.2 | 32   | 100 | 105  | 226  | 23.3   |

### ◆ BREAK-TORQUE VALUE (Nm / at 0 psi)

| SIZE       | 1/4" | 3/8" | 1/2" | 3/4" | 1"  | 1 1/4" | 1 1/2" | 2" | 2-1/2" | 3" | 4"  |
|------------|------|------|------|------|-----|--------|--------|----|--------|----|-----|
| FREASE     | 3.5  | 3.5  | 5    | 5.5  | 7   | 11     | 17     | 23 | 35     | 46 | 72  |
| NON-GREASE | 5    | 5    | 6    | 7    | 9.5 | 16     | 27     | 30 | 68     | 85 | 105 |

Note 1 : The greases use including lubricant & anti-size grease are both SILICONE-FREE.  
 Note 2 : Strongly suggest increasing at least 30%~40% for safety factor for mounting actuator.

Specification is subject to change without prior notice